

HUSKY

HUG-500S(E)



Industrial 5 10/100/1000TX

Gigabit Unmanaged Ethernet Switch

User's Manual

V2.0

6-26-2009

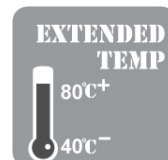

**Husky Series Industrial Ethernet Switch Solutions
HUG-500S(E) Industrial Gigabit Unmanaged Switch
User's Manual**

Copyright Notice

Copyright © 2009 Ethernet Direct Corp.

All rights reserved.

Reproduction in any form or by any means without Ethernet Direct prior written permission is prohibited.

Table of Contents

| | |
|---|------------|
| Chapter 1 Introduction | 1-1 |
| 1-1 Overview | 1-1 |
| 1-2 Product Features | 1-1 |
| 1-3 Package Checklist | 1-1 |
| Chapter 2 Hardware Installation | 2-1 |
| 2-1 Dimensions and Panel Layout | 2-1 |
| 2-2 LED Indicators | 2-2 |
| 2-3 RJ-45 Ports | 2-2 |
| 2-3.1 RJ-45 Pin Assignments | 2-2 |
| 2-4 Installing Your Ethernet Direct Switch..... | 2-3 |
| 2-4.1 Mounting The Switch..... | 2-3 |
| 2-4.2 Wiring The Power Inputs | 2-5 |
| 2-4.3 Wiring The Fault Alarm Contact..... | 2-6 |
| 2-4.4 Cabling..... | 2-6 |
| Appendix A Specifications | A-1 |
| Appendix B Troubleshooting | B-1 |

Chapter 1

Introduction

Welcome to Husky Series HUG-500S(E) Industrial Gigabit Unmanaged Ethernet Switch. This chapter includes the following topics:

- Overview
- Product Features
- Package Checklist

1-1 Overview

The Husky Series HUG-500S(E) Slim Gigabit Unmanaged Ethernet Switch is an entry-level industrial 5-port gigabit Ethernet switch that supports IEEE 802.3/802.3u/802.3x with 10/100/1000Mbps, full/half duplex and MDI/MDI-X auto-sensing RJ-45 ports. The compact, slim line switch is equipped with a relay output for an event alarm for easy troubleshooting. It offers a 12-48VDC redundant power input design and is secured with power polarity reverse protection and an overload current reset-table fuse. Its IP-30 housing protection, wide operating temperature of -10 to 70°C and DIN-Rail mounting is suitable for an industrial environment. The E version has extended operation temperature range of -40 to 80°C. The HUG-500S is a plug-and-play solution for your industrial Ethernet applications.

1-2 Product Features

HUG-500S(E) has the following features:

High Performance Network Switching Technology

- Complies with IEEE 802.3, IEEE 802.3u, IEEE 802.3x, IEEE 802.3ab
- Provides 5 x 10/100/1000Mbps Ethernet ports with RJ-45 connector
- Supports IEEE 802.3x flow control on full duplex, back pressure on half duplex
- RJ-45 ports support auto MDI/MDI-X crossover
- Provides broadcast storm protection

Robust Industrial Design

- Robust aluminum case complying to IP-30 housing standard
- Supports operating temperature -10 to 70°C & extended temperature -40 to 80°C
- DIN-Rail, wall mounting installation
- High level of immunity to electromagnetic interference & power supply surges typically found in industrial plant environments or external curb side enclosures

Reliable Power Design

- Supports 6000VDC Ethernet ESD protection
- Provides surge (EFT) protection 3000VDC for power line
- Supports redundant 12 to 48VDC
- Power polarity reverse protection
- Removable terminal block

1-3 Package Checklist

HUG-500S(E) is shipped with the following items:

- 1 x Husky Series HUG-500S(E) Industrial Slim Gigabit Unmanaged Ethernet Switch
- 1 x User's manual
- 2 x wall-mounting plates and 6 x screws
- 1 x DIN-Rail mounting kit (attached to the HUG-500S(E)'s back panel by default)



IF DC voltage is supplied by an external circuit, please use a protection device on the power supply input.

Chapter 2

Hardware Installation

This chapter contains information on HUG-500S(E)'s dimensions and hardware installation. Topics include:

- Dimensions and Panel Layout
- LED Indicators
- RJ-45 Ports
- Installing Your Ethernet Direct Switch

2-1 Dimensions and Panel Layout

Dimensions of HUG-500S(E) Industrial Gigabit Managed Switch are 30mm (W) x 95mm (D) x 140mm (H).

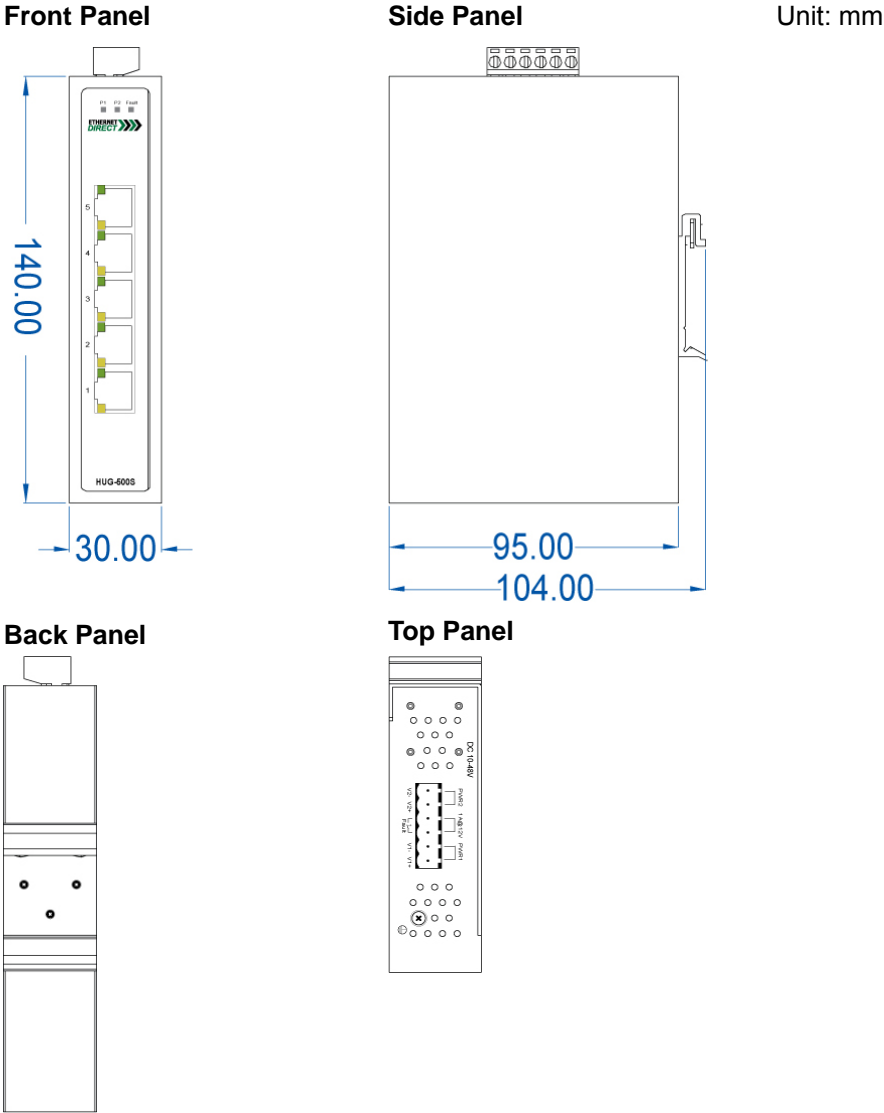

2-2 LED Indicators

There are diagnostic LEDs located on the front panel of HUG-500S(E). They provide primary information on switch status as described in the table below.

| LED Name | LED Color | LED Function |
|---------------------|----------------|---|
| P1 | Green | Power input 1 is on. |
| | Off | Power input 1 is off or no power is being supplied to the switch. |
| P2 | Green | Power input 2 is on. |
| | Off | Power input 2 is off or no power is being supplied to the switch. |
| Fault | Red | Power input 1 or 2 is inactive. |
| | Off | Power input 1 and 2 are both functional, or no power inputs. |
| 1-5 (Green LED) | Green | The port is connected to a network. |
| | Blinking Green | The port is transmitting or receiving data. |
| | Off | The port is not connected to a network. |
| 1-5 (Orange LED) | Orange | The port is connected to a network at 1000Mbps. |
| | Off | The port is not connected to a network. |

2-3 RJ-45 Ports

HUG-500S(E) has 5 10/100/1000Mbps auto-sensing ports for 10Base-T, 100Base-TX, or 1000Base-TX devices connection. The UTP ports can auto-sense for 10Base-T, 100Base-TX, or 1000Base-TX connections. Auto MDI/MDIX function allows HUG-500S(E) to connect to another switch or workstation without changing straight through or crossover cabling. See **Cabling** section for straight through and crossover cable schematic.

2-3.1 RJ-45 Pin Assignments

RJ-45 pin assignments as described in the table below:

| Pin Number | Assignment |
|------------|------------|
| 1 | Tx+ |
| 2 | Tx- |
| 3 | Rx+ |
| 6 | Rx- |



“+” and “-” signs represent the polarity of the wires that make up each wire pair.

All ports on HUG-500S(E) support automatic MDI/MDI-X function, users can use straight-through cables (see figure below) for all network connections to PCs or servers, or to other switches or hubs. When auto MDI/MDI-X is enabled, either type of cable can be used and the interface automatically corrects any incorrect cabling. The table below shows the 10Base-T/100Base-TX MDI and MDI-X port pinouts.

| Pin | MDI | MDI-X |
|-----|-----|-------|
| 1 | TD+ | RD+ |
| 2 | TD+ | RD- |
| 3 | RD+ | TD+ |

| | | |
|---|-----|-----|
| 6 | RD- | TD- |
|---|-----|-----|

Below are the illustrations of straight through connection and cross over connection.

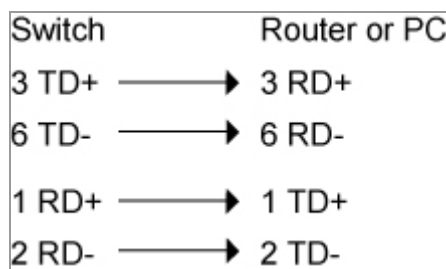

Straight Through Cable Schematic

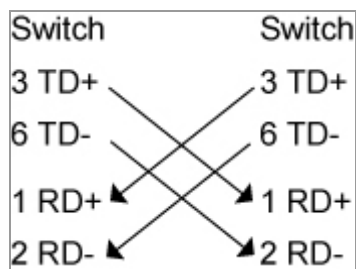

Cross Over Cable Schematic

2-4 Installing Your Ethernet Direct Switch

Unpack the HUG-500S(E) from the packing box. Please refer to **Package Checklist** section to see if any item is missing or damaged. The installation steps include **Mounting The Switch**, **Wiring The Power Inputs**, **Wiring The Fault Alarm Contact**, and **Cabling**.

2-4.1 Mounting The Switch

There are two types of mounting options: DIN-Rail mounting, and wall mounting. Users can choose the most suitable mounting installation for your own onsite applications.

2-4.1.1 DIN-Rail Mounting

The DIN-Rail mounting kit is attached to the back panel of HUG-500S(E) by default. If not, or users want to disassemble the DIN-Rail mounting kit from the HUG-500S(E), follow the steps below.

To attach the DIN-Rail mounting kit:

1. Screw the DIN-Rail kit to the position shown in the figure below.
2. To detach DIN-Rail kit from the switch, reverse the step 1.

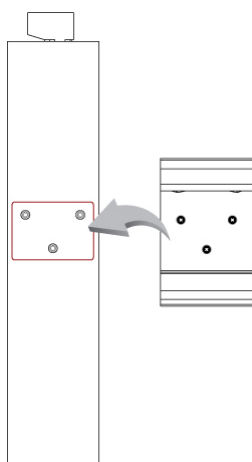

Follow the steps below for mount the switch onto the track.

1. Insert the top of DIN-Rail plate into the track.

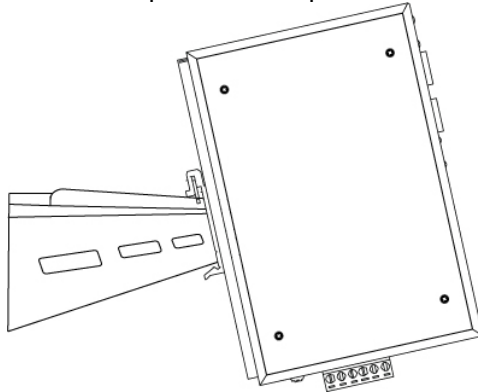

2. Lightly push the DIN-Rail plate into the track.

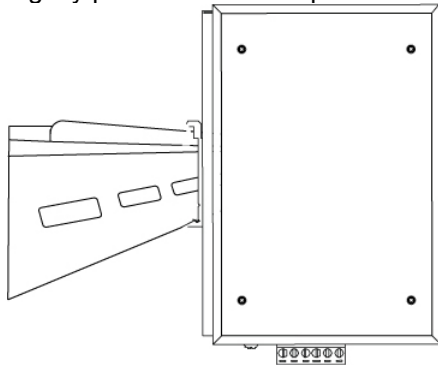

3. Check if the DIN-Rail is tightened on the track or not.
4. To remove the switch from the track, reverse steps above.

2-4.1.2 Wall Mounting

Follow the steps below for wall-mounting installation.

1. Remove the DIN-Rail plate from the switch; loosen the screws to remove the DIN-Rail plate.
2. Place the 2 wall mounting plates on the top and bottom panel of the switch respectively.
3. Use the screws to screw the wall mounting plates on the switch.
4. Use the hook holes at the corners of the wall mounting plates to place the switch on the wall.
5. To remove the wall mounting plates, reverse the steps above.

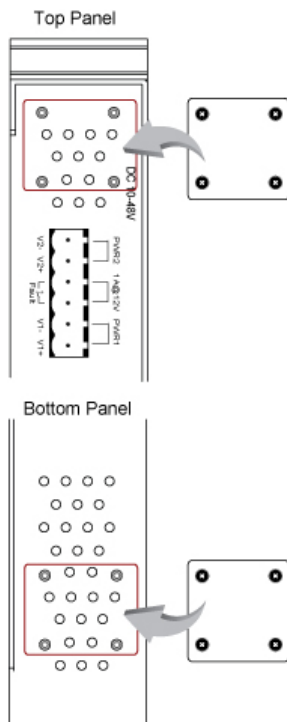

2-4.2 Wiring The Power Inputs

Follow the steps below to wire the power inputs.



Be sure to disconnect the power cord before installing and/or wiring your switch.
 Be sure of the maximum possible current when wiring connections. If the current goes above the maximum ratings, the wire could overheat and result in serious damage to your switch.

1. Insert the positive and negative wires of your DC supply into the corresponding V+ and V- contacts of the terminal block.

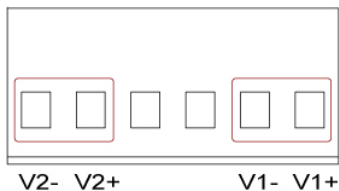

2. Tighten the screws to prevent the DC wires from coming detached.

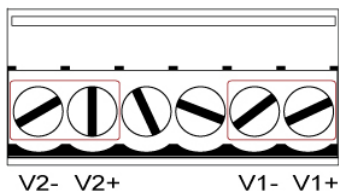

The acceptable wire range is 12 to 24 AWG.

2-4.3 Wiring The Fault Alarm Contact

The fault alarm contacts are the two middle terminals located on the terminal block as show in the figure below. It detects errors such as power failure or port break and sends an alarm signal when faults occur. By default, the fault alarm contacts will form an open circuit under normal operation. The contacts will close when power failures or port breaks are detected. See below steps for wiring the fault alarm contact, and the illustration of how fault alarm contact function works.

1. Insert the wires into the two middle terminals. Tighten the screws to prevent the wires from coming detached.

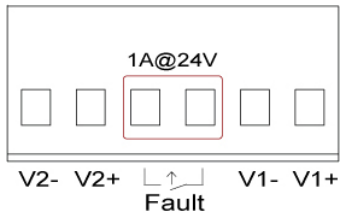

The acceptable wire range is 12 to 24 AWG.

2-4.4 Cabling

For RJ-45 port connection, prepare twisted-paired, straight through Category 5 cables for Ethernet connection. The linking distance between the switch and the network device must be less than 100 meters (328 ft.).

For 10Mbps connections, use 100Ω Category 3, 4 or 5 cables.

For 100Mbps connections, use 100Ω Category 5 cables.

For 1000Mbps connections, use 100Ω Category 5e or above cables.

The UTP port (RJ-45) LED(s) on the switch will light up when the cable is connected with the network device. Please refer to the LED Indicators section for more information.



Before connecting any network device, make sure network devices support auto MDI/MDI-X. If not support, use the cross over Category 5 cables.

After all wiring and connection are done and the LED lights on the switch's front panel show normal status, the hardware installation is complete.

Appendix A

Specifications

HUG-500S(E) Product Specifications are as follows:

| Hardware | | |
|-----------------------------|--|--|
| <i>Interface</i> | | |
| RJ-45 Ports | 5 10/100/1000Base-TX auto-negotiation speed, Full/Half duplex mode, auto auto MDI/MDI-X connection | |
| LEDs | Per Unit | Power 1 (Green), Power 2 (Green), Fault (Red) |
| | Per Port | Link/Activity (Green), Speed (1000Mbps Green) |
| Power Input | 12-48VDC, redundant power with removable terminal block | |
| Power Protection | ESD (Ethernet) 6000VDC, Surge 3000VDC, Power Reverse Polarity | |
| Power Consumption | 5 watts | |
| Dimensions | IP-30, 30mm (W) x 95mm (D) x 140mm (H) | |
| Installation | DIN Rail mounting/Wall mounting | |
| <i>Environmental</i> | | |
| Operating Temp | Regular: -10 to 70°C Extended: -40 to 80°C | |
| Storage Temp | -40 to 85°C | |
| Operating Humidity | 5% to 90% RH (non-condensing) | |
| Technology | | |
| Standards | IEEE 802.3 for 10BaseT IEEE 802.3u for 100BaseT(X) IEEE 802.3ab for 1000BaseT(X) IEEE 802.3x for Flow Control | |
| Network Media | 10BaseT | 2-pair UTP/STP Cat. 3, 4, 5/5E cables EIA/TIA-568 100Ω (100m) |
| | 100BaseT(X) | 2-pair UTP/STP Cat. 5/5E cables EIA/TIA-568 100Ω (100m) |
| | 1000BaseT(X) | 2-pair UTP/STP Cat. 5/5E cables EIA/TIA-568 100Ω (100m) |
| Protocols | CSMA/CD | |
| Switching Architecture | Store and Forward | |
| Regulatory Approvals | | |
| EMI | FCC Class A | |
| EMS | EN61000-4-2, EN61000-4-3 EN61000-4-4 EN61000-4-5 EN61000-4-6 EN61000-4-8 EN61000-4-11 | |

| | |
|-------------------|--|
| | EN61000-4-12 EN61000-6-2 EN61000-6-4 |
| Safety | UL, cUL, CE/EN60950-1 |
| Shock | IEC60068-2-27 |
| Vibration | IEC60068-2-6 |
| Free Fall | IEC60068-2-32 |
| Class 1 Divison 2 | Pending |
| DNV | Pending |
| Environmental | WEEE, RoHS |
| MTBF | 325,000 hrs based on Mil-Hdbk-217F, GB |
| Warranty | 5 years |

Appendix B

Troubleshooting



Make sure you are using the right power cord/adaptor (DC 12-48V). Do not use power adapters with DC output higher than 48V. Or it will short circuit the switch.



Select the proper UTP cables to construct your network. Please check that you are using the right cables. Use unshielded twisted-pair (UTP) or shield twisted-pair (STP) cables for RJ-45 connections: 100Ω Category 3, 4 or 5 cables for 10Mbps connections, 100Ω Category 5 cables for 100Mbps, or 100Ω Category 5e/above cables for 1000Mbps connections. Also be sure that the length of any twisted-pair connection does not exceed 100 meters (328 feet).



Diagnostic LED indicators located on the front panel of the switch can help users to easily monitor the switch.



IF the power indicator does not light on when the power cord is plugged in, you may have a problem with power cord. Then check for loose power connections, power losses or surges at power outlet. IF you still cannot resolve the problem, contact your local dealer for assistance.



If the switch LED indicators are normal, the cables are connected correctly, and the packets still cannot transmit, please check your system's Ethernet devices' configuration or status.